

# Timing analysis pipeline

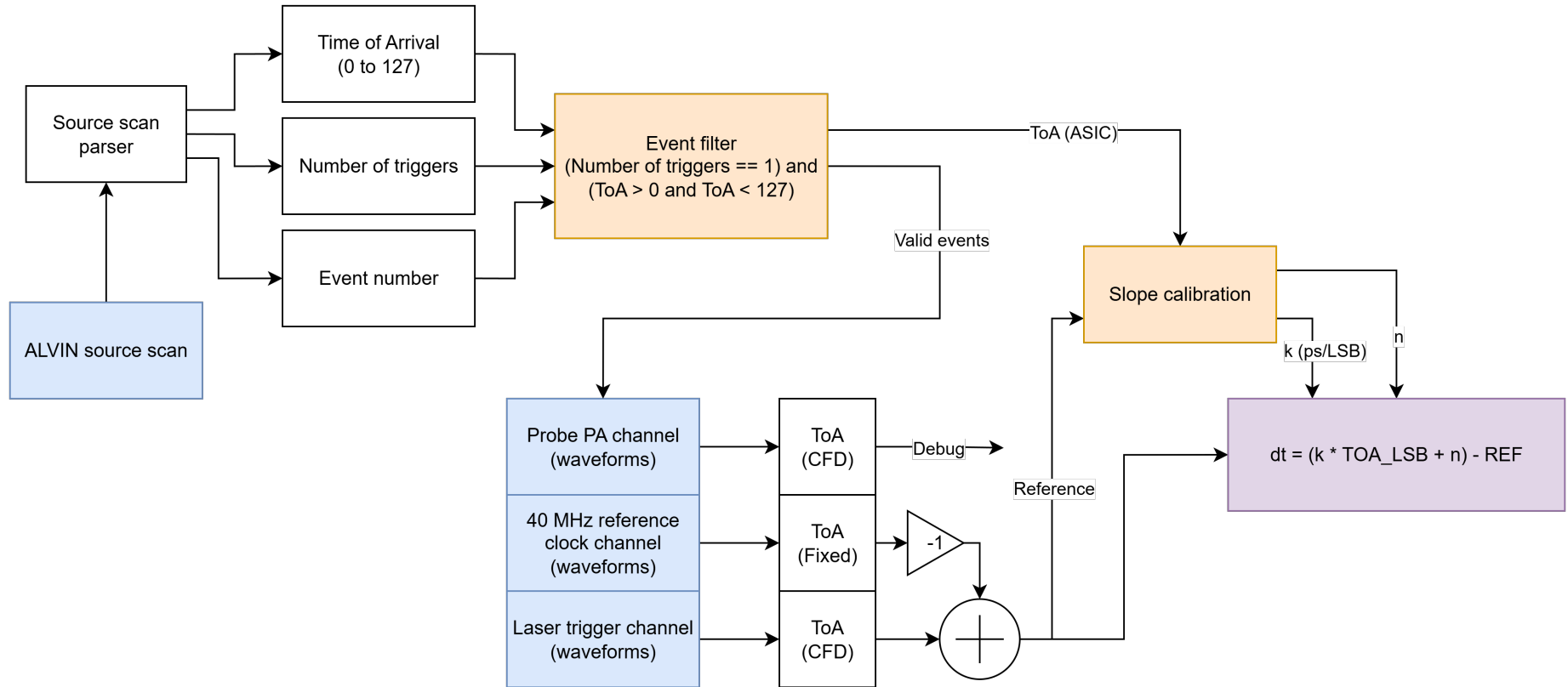

# ASIC data parser

- Parser included in TOAST has some issues when parsing data with current measurement setup
- Empty trigger events cause misalignment and incorrect event matching
- What causes spurious empty triggers is still unknown

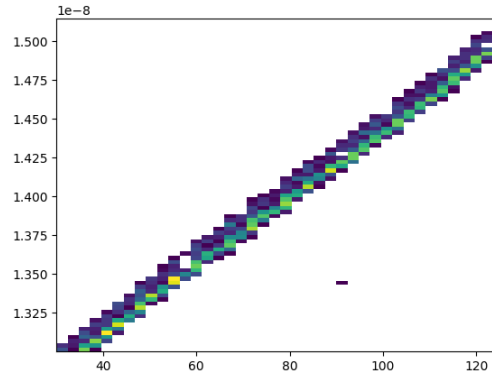
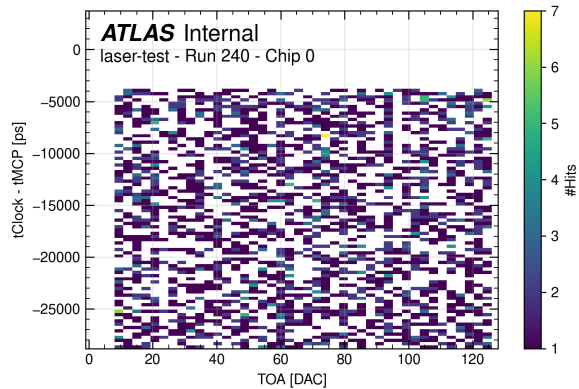

## INPUT

```

1 1 0 0 276 56 0
0 8 10 2480 127 16 2
2
1 2 0 0 277 57 0
3 805 152696488
3 806 152696488
3 807 152696488
52428 0 0 #Module Chip
3 808 23884
1 0 0 0 381 59 0
2
1 1 0 0 382 60 1
0 8 10 2480 67 16 2
    
```

## OUTPUT

```

{'ntrigger': 0,
 'timestamp': 22442,
 'headers': [{'trig_num': 0,
 'frame_type': 0,
 'err': 0,
 'bcid': 482,
 'lvl1': 24,
 'pb': 1},
 {'trig_num': 1, 'frame_type': 0, 'err': 0,
 'bcid': 483, 'lvl1': 25, 'pb': 1},
 {'trig_num': 2, 'frame_type': 0, 'err': 0,
 'bcid': 484, 'lvl1': 26, 'pb': 0},
 {'trig_num': 3,
 'frame_type': 0,
 'err': 0,
 'bcid': 485,
 'lvl1': 27,
 'pb': 0}],
 'data': [{'trig_num': 2,
 'row': 10,
 'col': 8,
 'totps': 3040,
 'toa': 127,
 'totc': 20,
 'totf': 4}],
 'chunk': 0}
    
```

# Event filter

Process only events inside 2.5 ns measurement window

- Event must have valid ToA ( $> 0$  and  $< 127$ )
- Only 1 trigger (no noisy data)
- Only 10% of triggers fall into measurement window (40 MHz clock - 25 ns, 2.5 ns window)
- Use only filtered events in timing analysis

# Parameter extraction

From each waveform extract ToA information

- Use CFD for laser trigger (rising edge) and PA probe
- Use fixed threshold for clock (very stable very little change across event space)

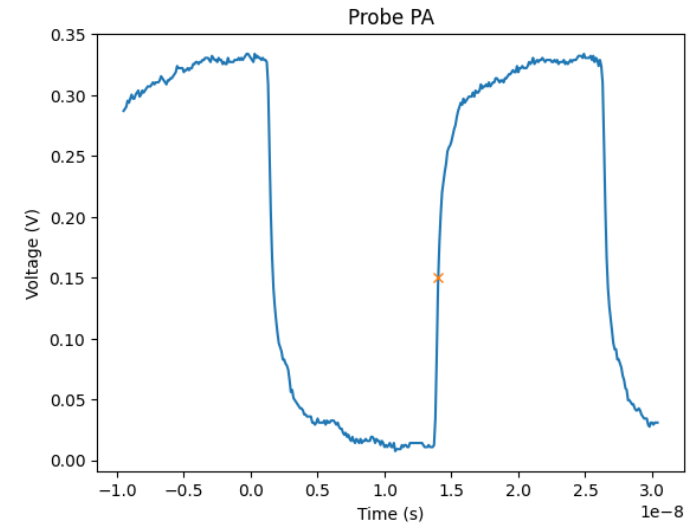
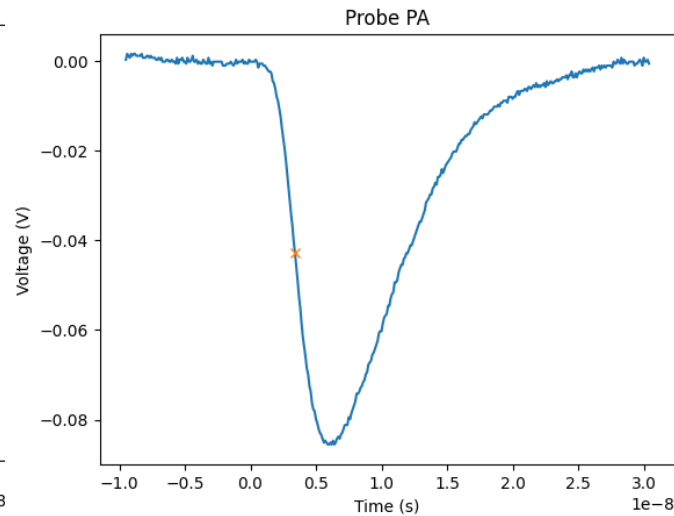
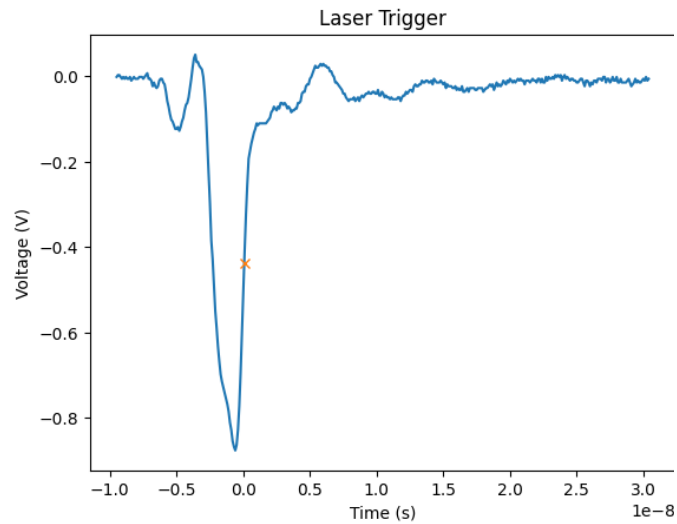

# Persistence plots

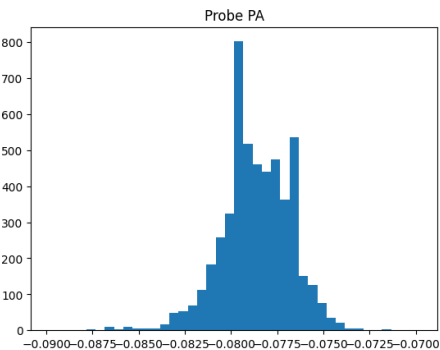
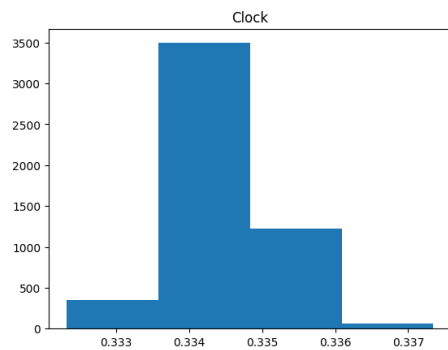
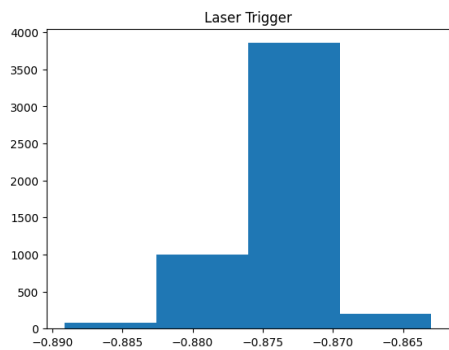
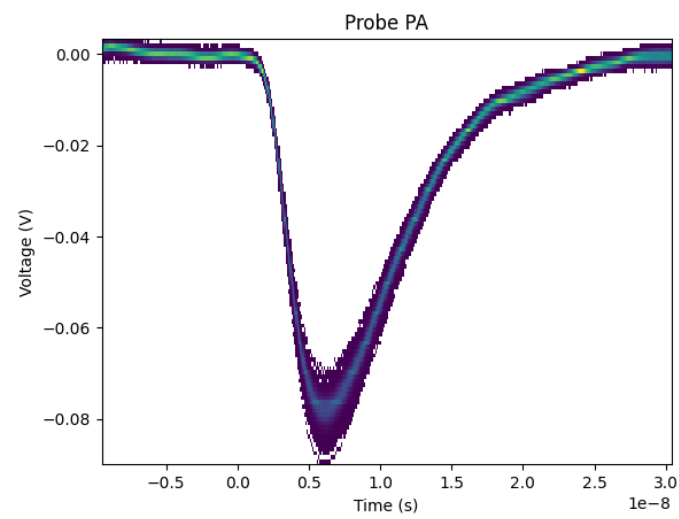
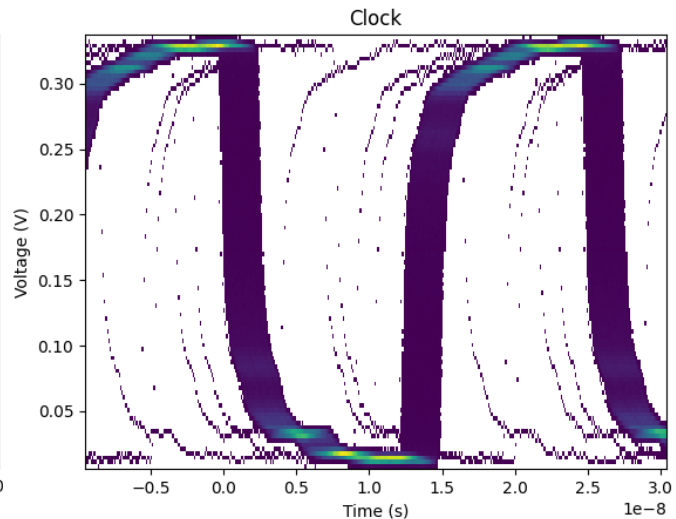
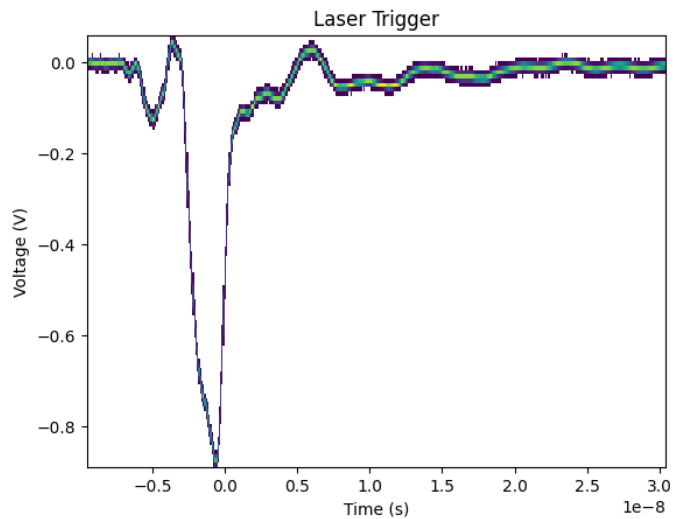

# Asic data and digitizer event correlation

Correctly matched ASIC and digitizer data produces correlation plot showing clear dependence between ToA code and measured time difference between laser trigger and clock edge.

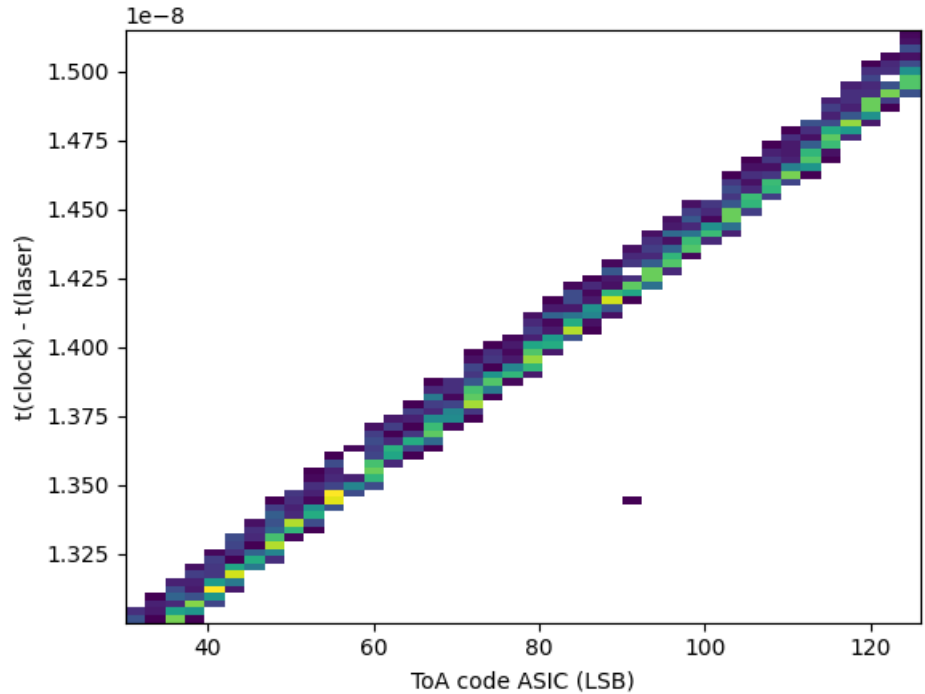

# ToA code calibration

Linear fit

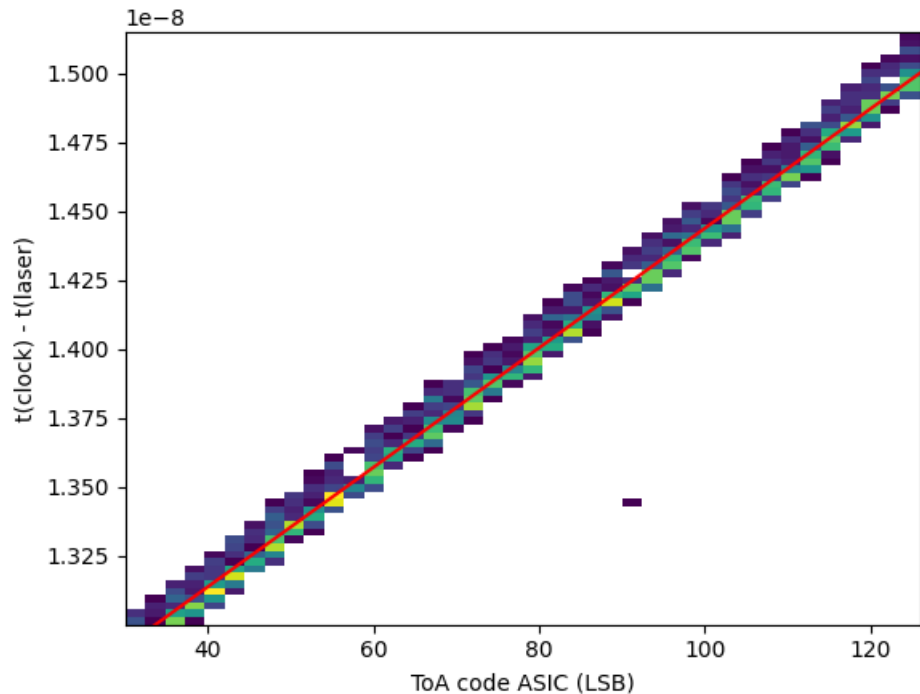

**$k = 21.67 \text{ ps}$**

Value different from 20 ps indicates delay line voltages are not yet tuned perfectly.

Subtracting expected value from measured value

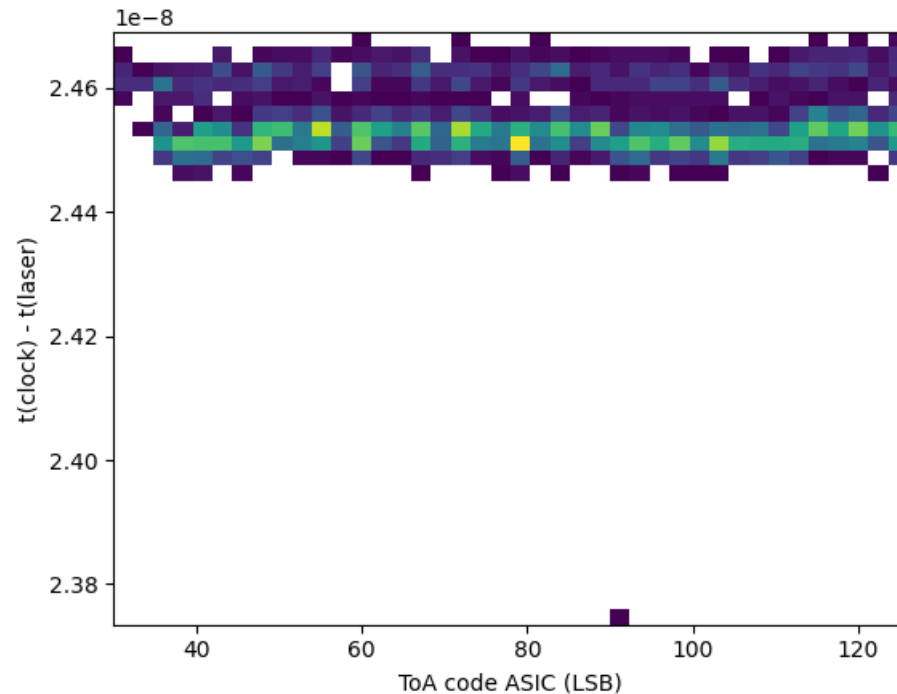

# Time resolution

$$t_{\text{ref}} = t_{\text{clk}} - t_{\text{trig}}$$

$$\Delta t = kC + n - t_{\text{ref}}$$

Time resolution is calculated by first calculating reference time and subtracting this reference time from expected value from ASIC code C.

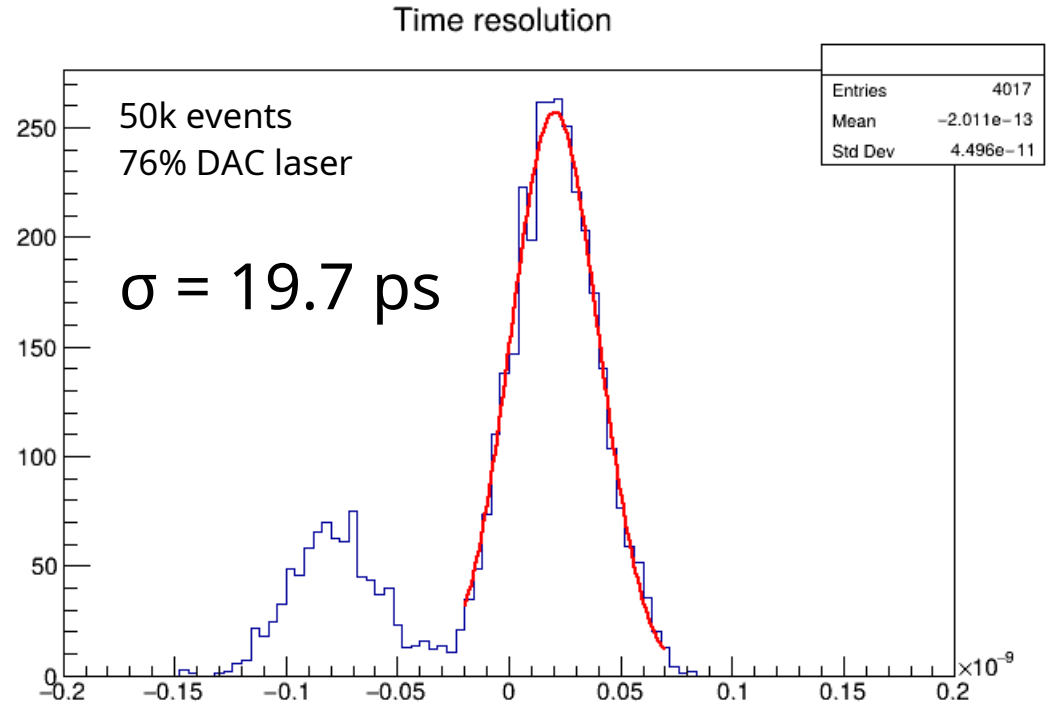

# ASIC distributions

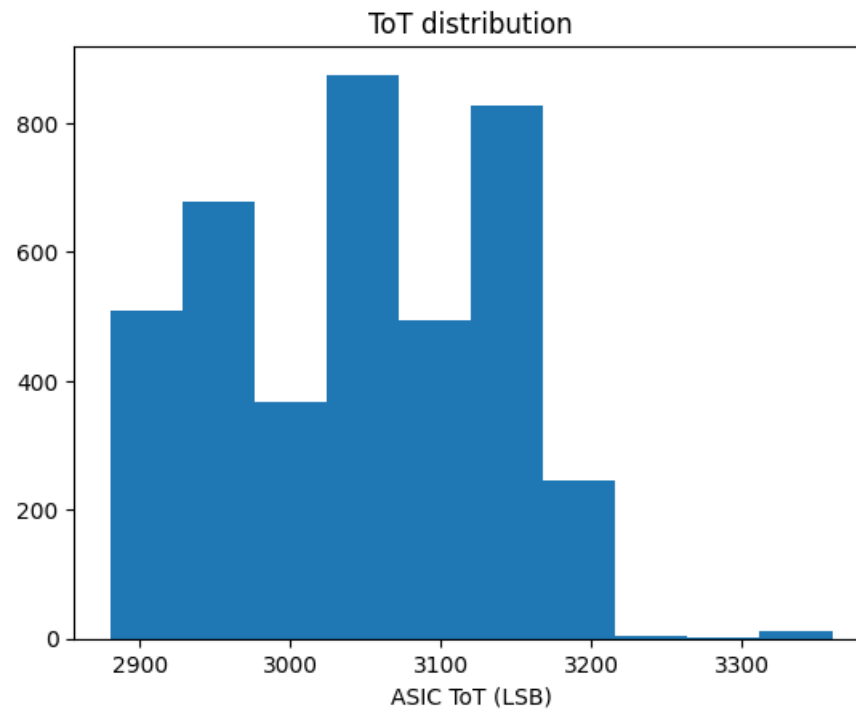
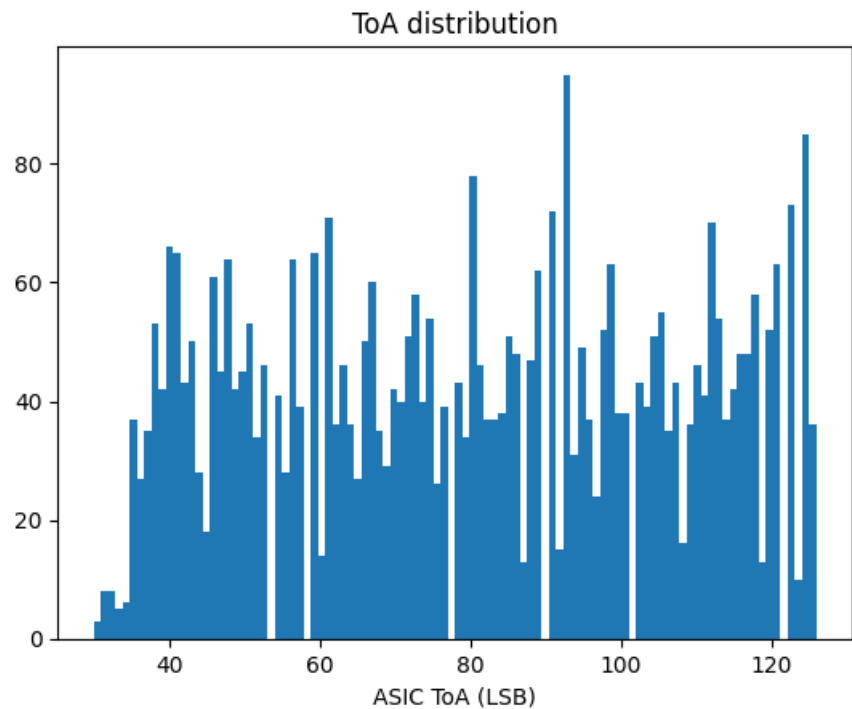

# Double peak issue

From previous campaign

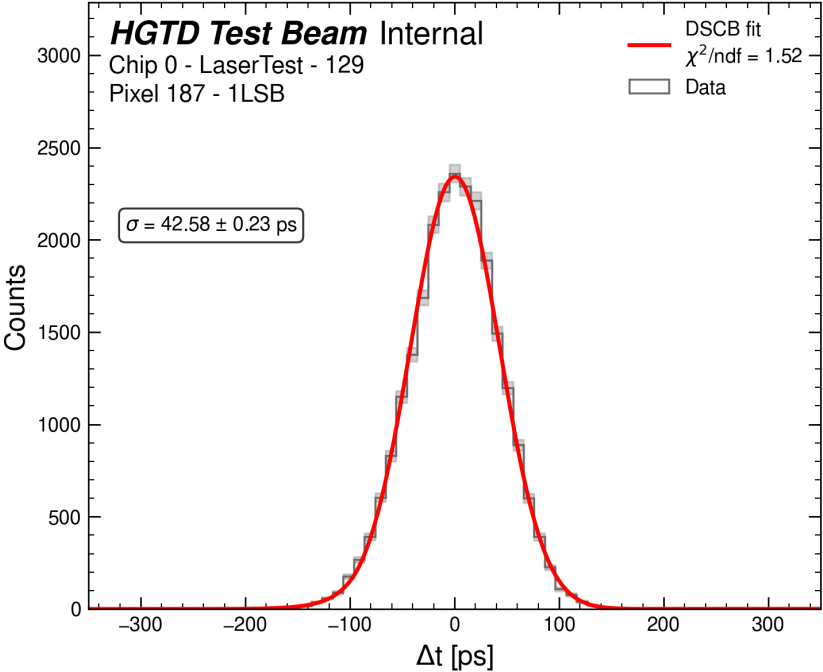

Time resolution

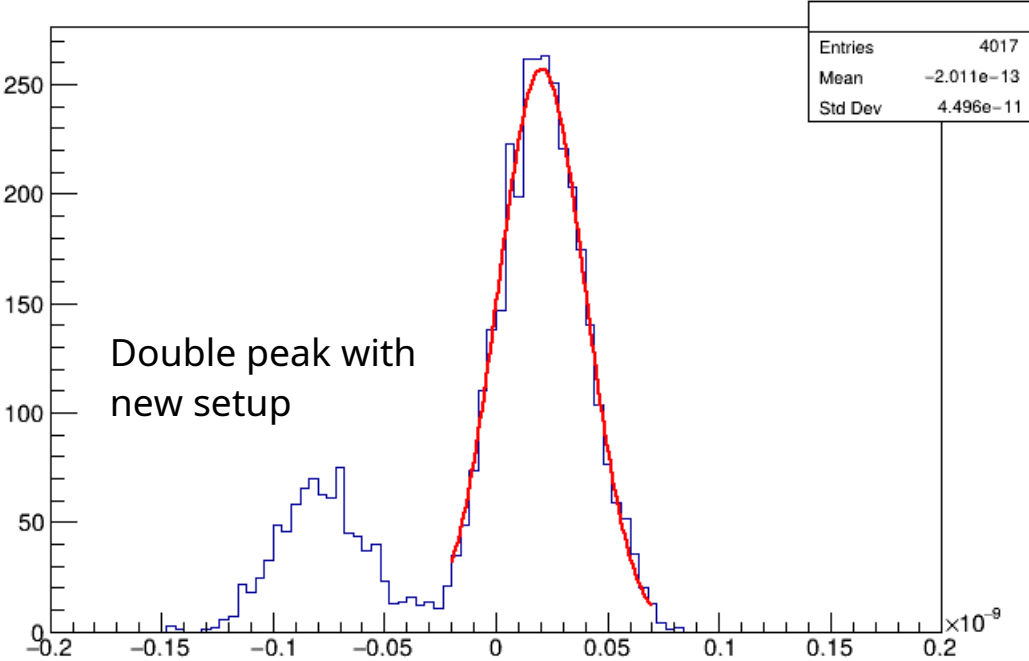

# Strange behavior in analog signal path

Strange discontinuous correlations between ToA of probe output and MCP (laser trigger) ToA...

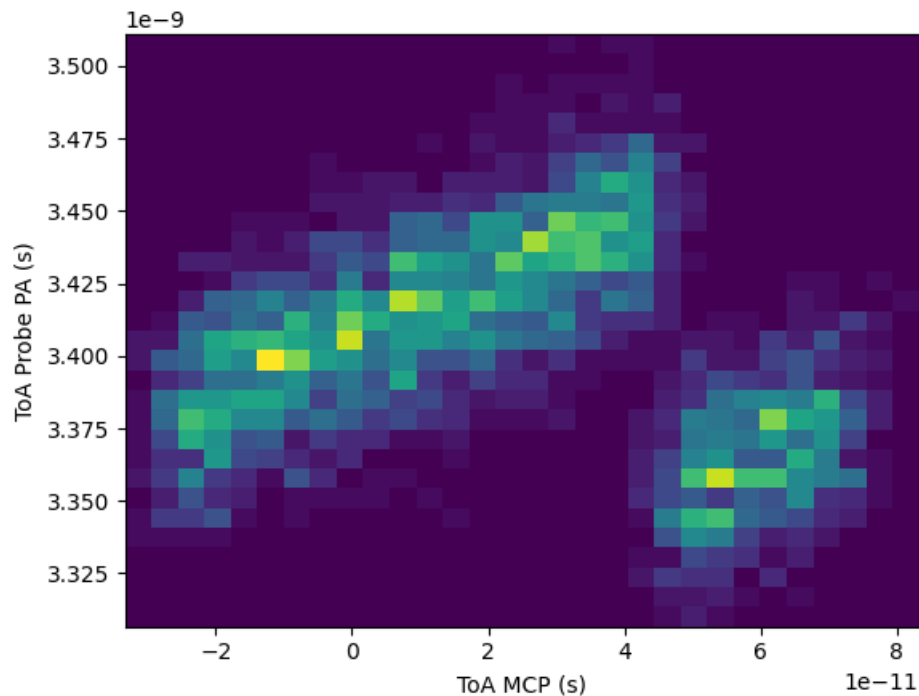
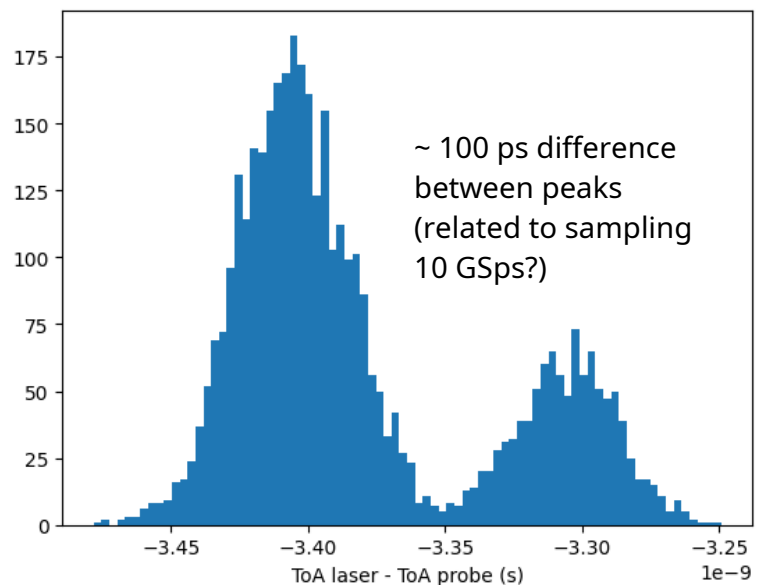

# Correlations of analog signals

2 Different regions?

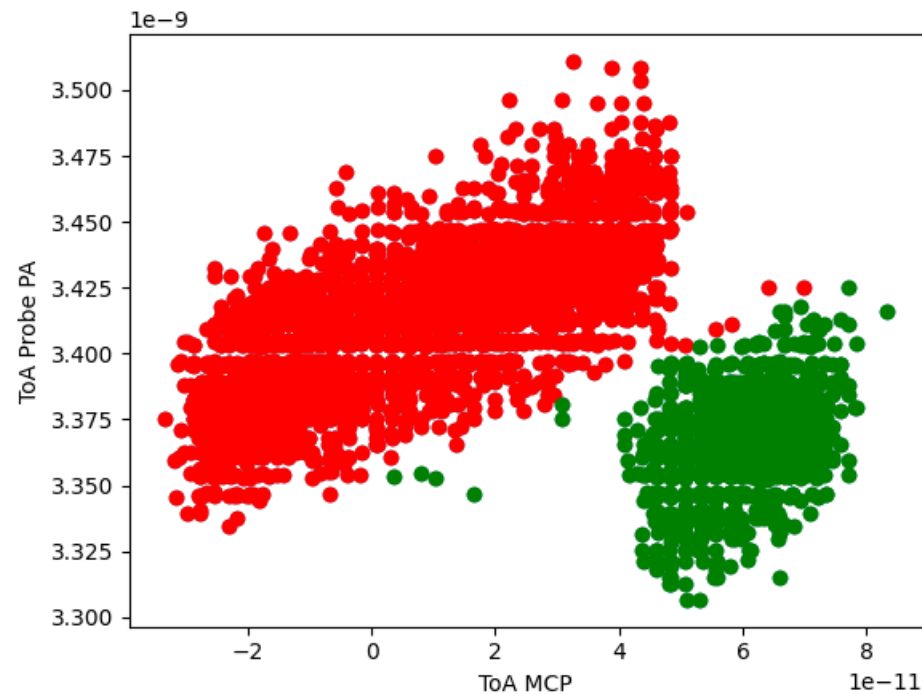
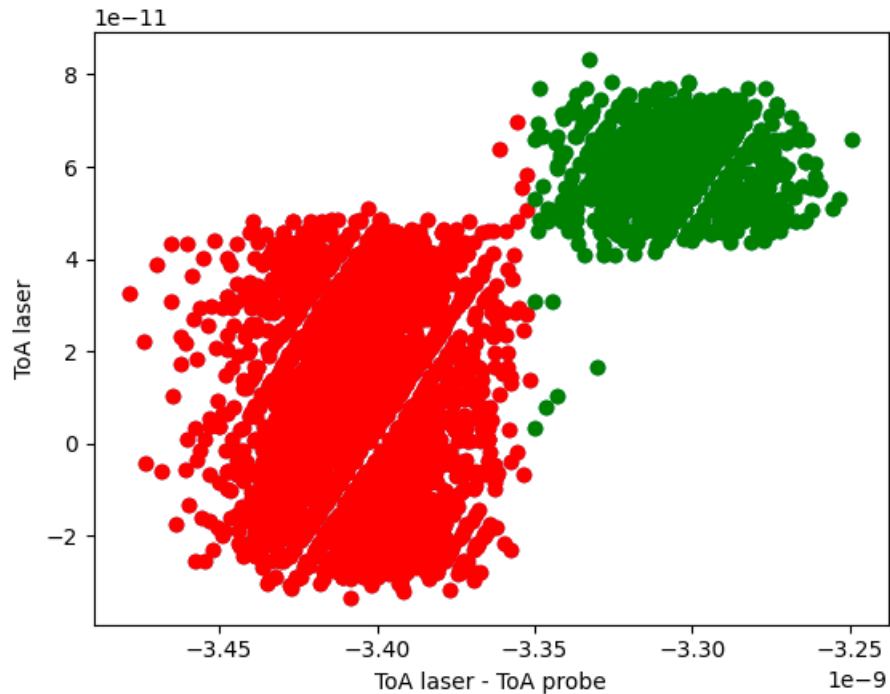

# Correlation with time delta

3 different regions of operation (all with error of about 100 ps - sampling issues, off by one?)

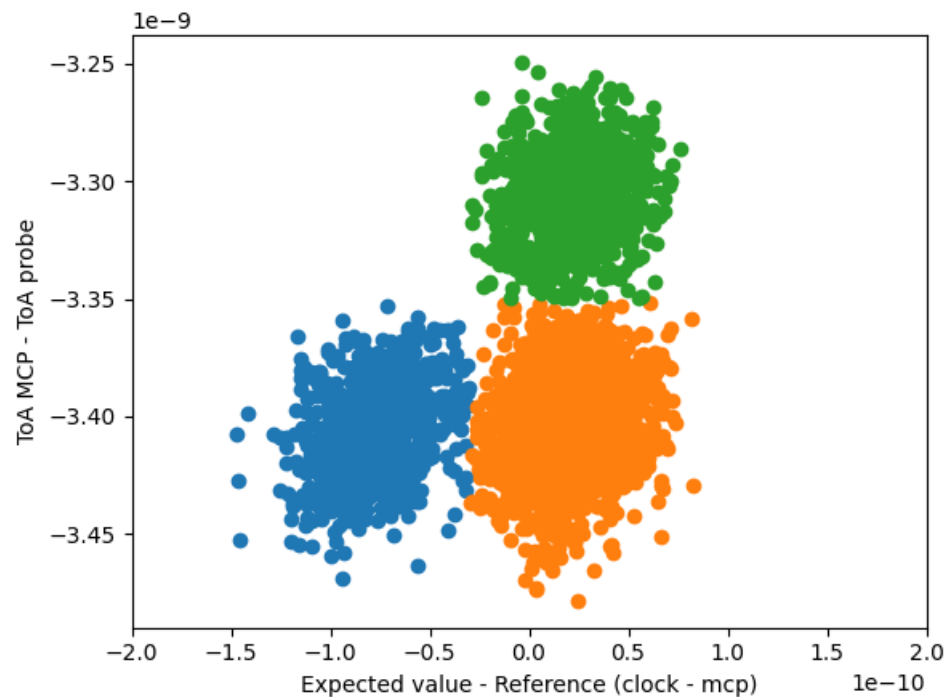
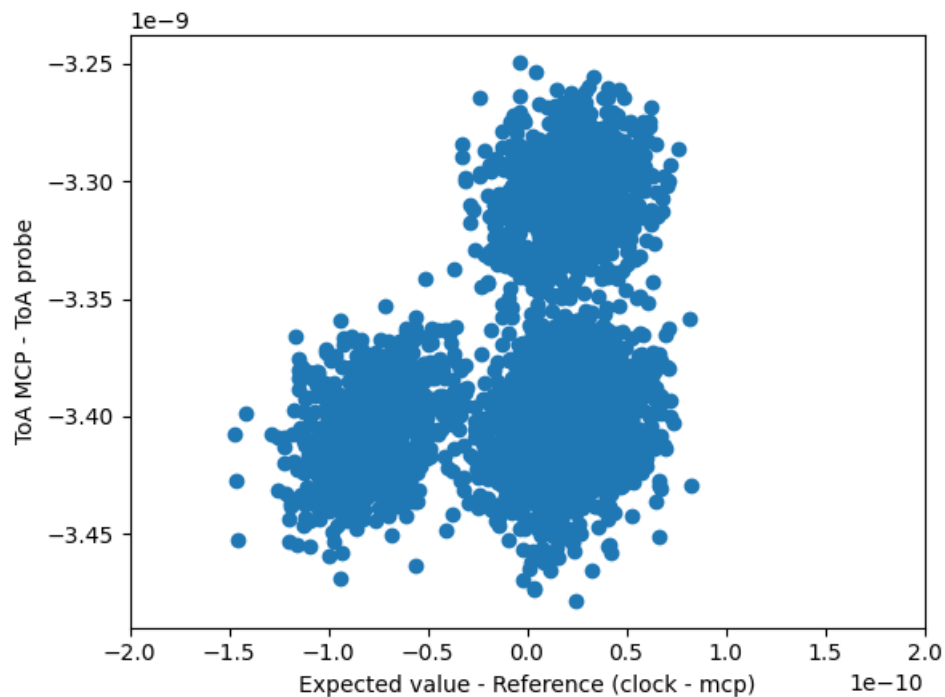

# Processing regions separately

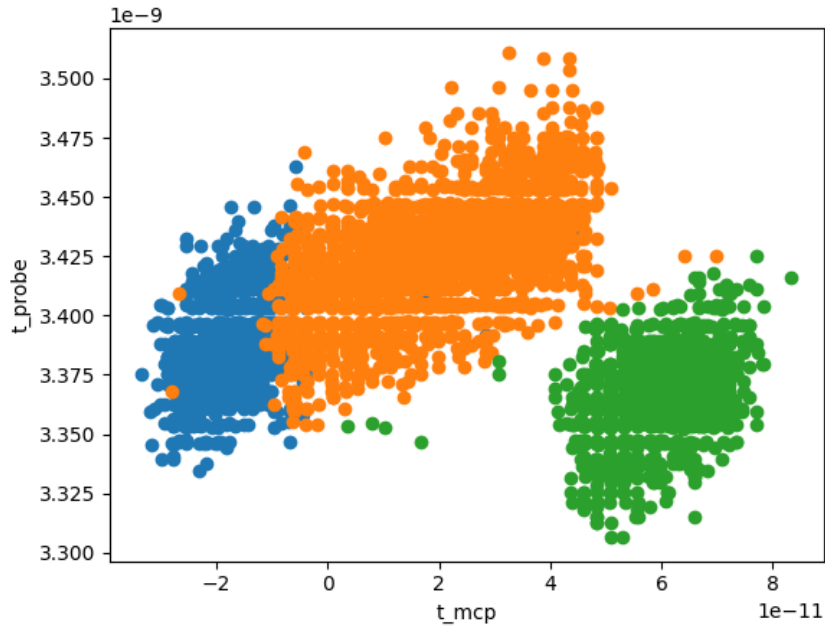

Processing by region seems to resolve double peak issue, but cause is still unknown. Most likely something to do with DAQ, possibly test using different digitizer?

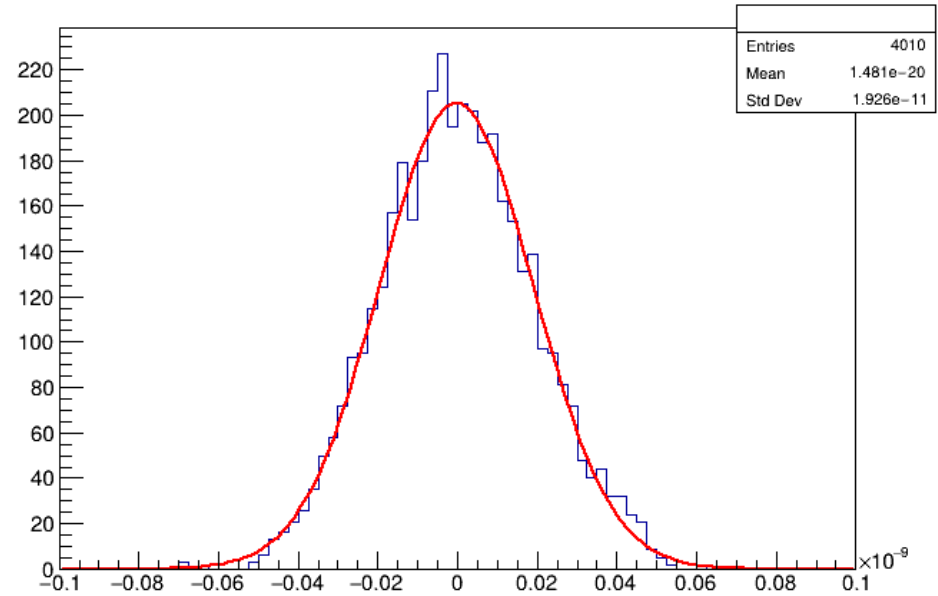

Chi2	=	43.6461		
Ndf	=	43		
Edm	=	1.01723e-05		
NCalls	=	53		
Constant	=	205.36	+/-	4.04111
Mean	=	-1.30357e-13	+/-	3.14797e-13
Sigma	=	1.93574e-11	+/-	2.34492e-13

# Using TOAST for analysis (different data set)

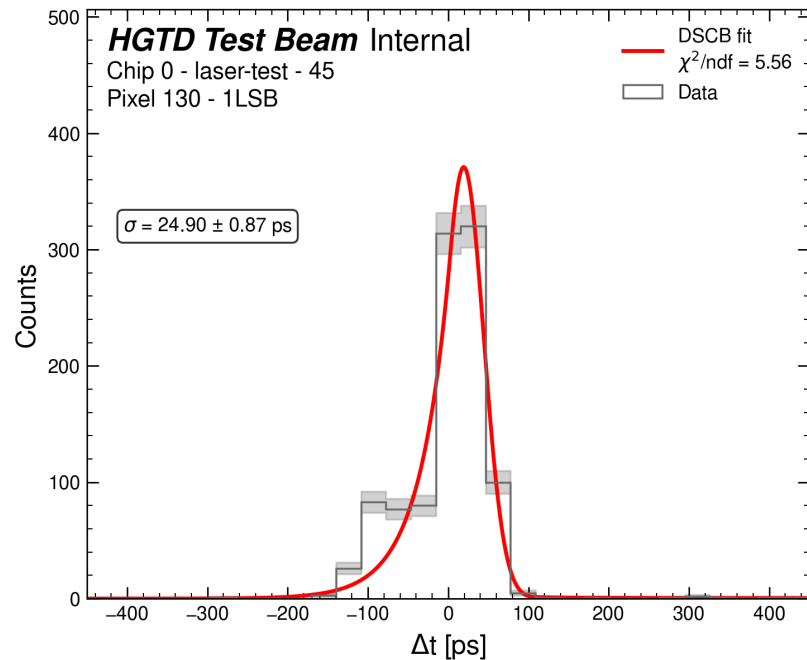
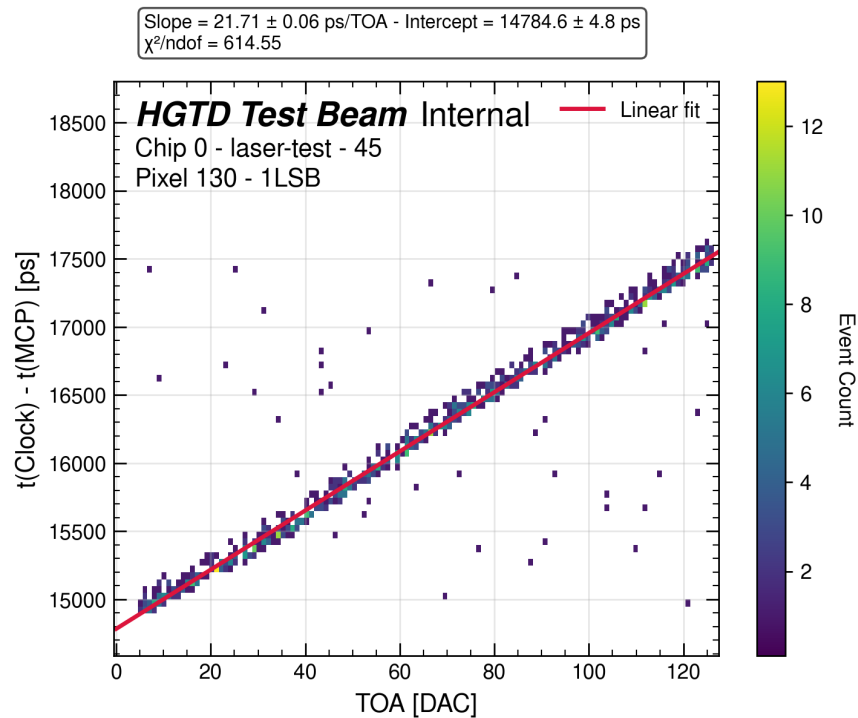

# HGTD Test Beam Internal

Chip 0 - laser-test - 45

Saturated: 81.31% - TOA=0: 8.78%

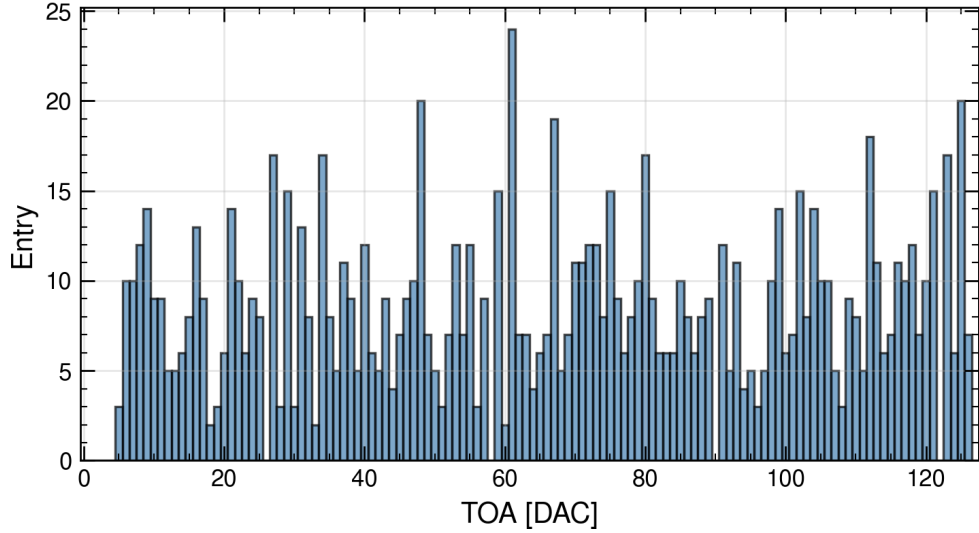

# HGTD Test Beam Internal

Chip 0 - laser-test - 45

MPV: 2800 ps - TOT=0: 8.95%

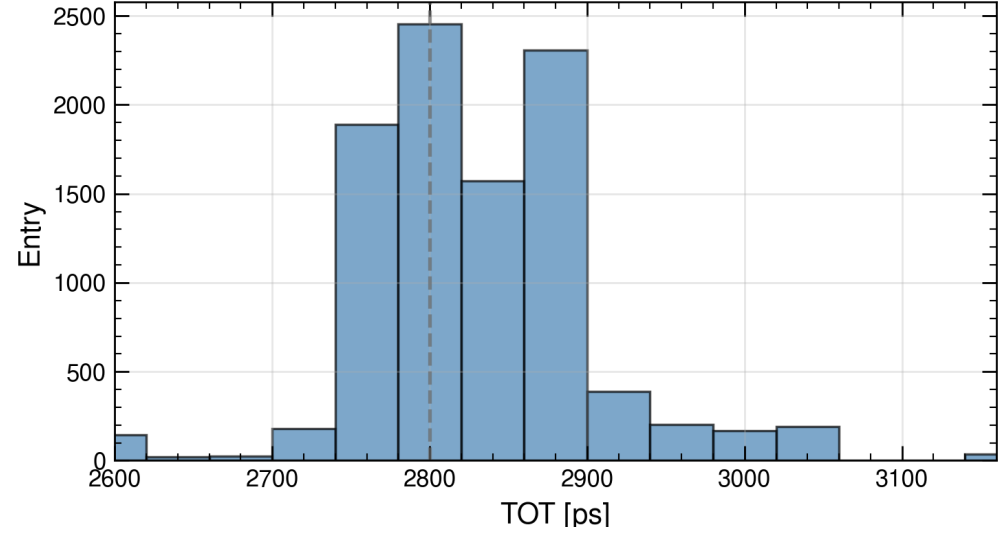

RUN 45

