



IFIGENEIA

Innovative Facility for Isotope GENERation
with Efficient Ion Accelerator

Deliverable D3.1 - LINAC-RFQ prototype design

Dimitrios Lamboudis

YFOS



This project has received funding from the European Union's Horizon Europe
Research and Innovation Programme under the Grant Agreement No.101186921.



LINAC-RFQ Prototype

All the information presented regarding the drawings, the machining strategy, the heat treatment and the technical specifications, have been provided by CERN.

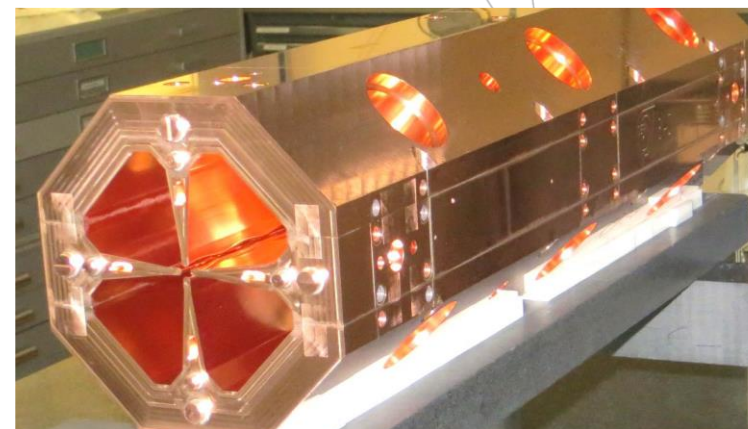
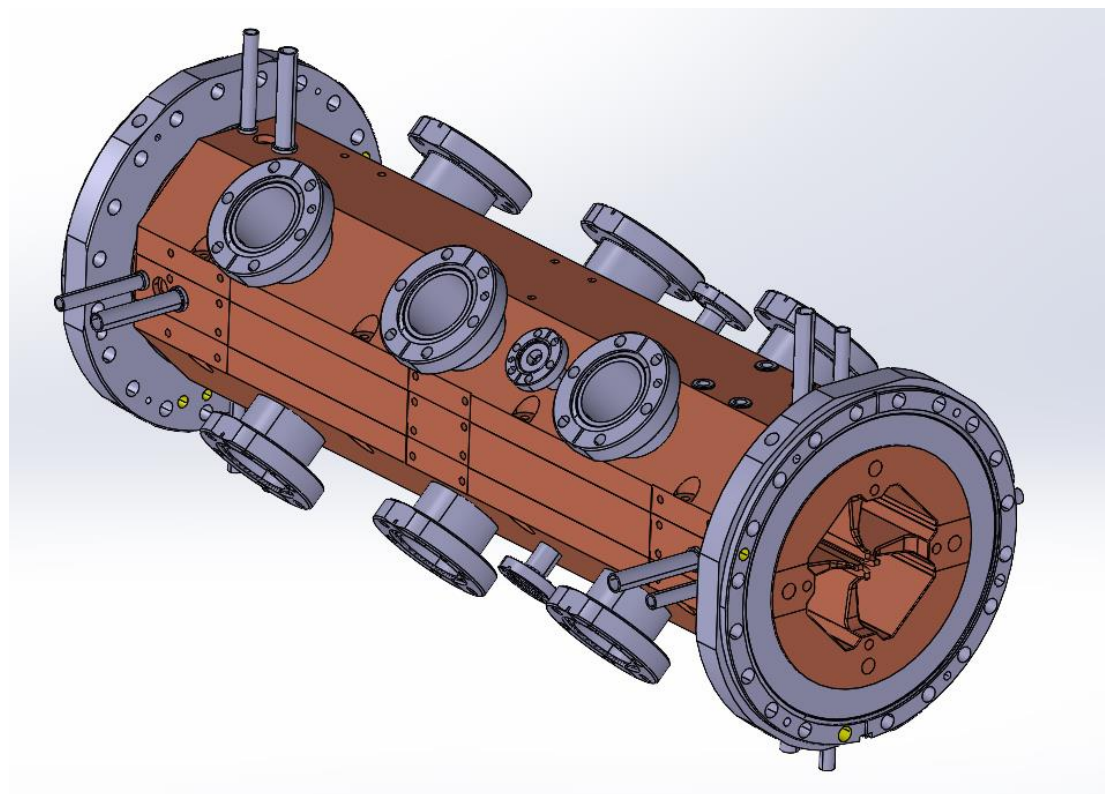



LINAC-RFQ Prototype

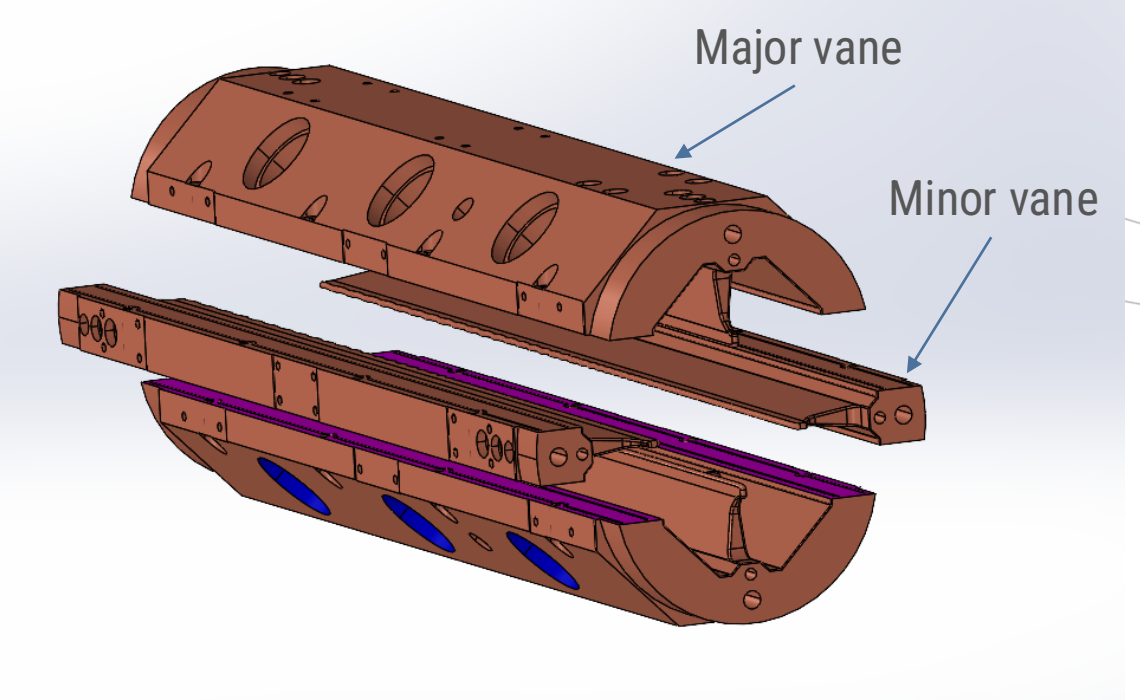
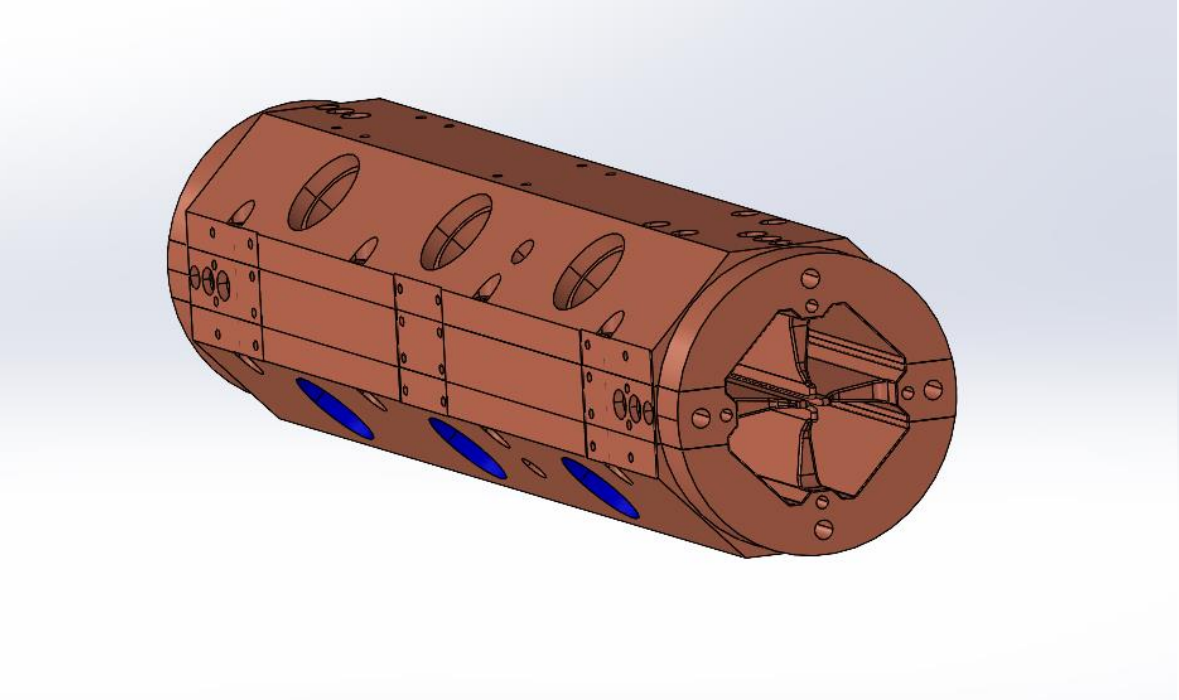



Stock material specifications

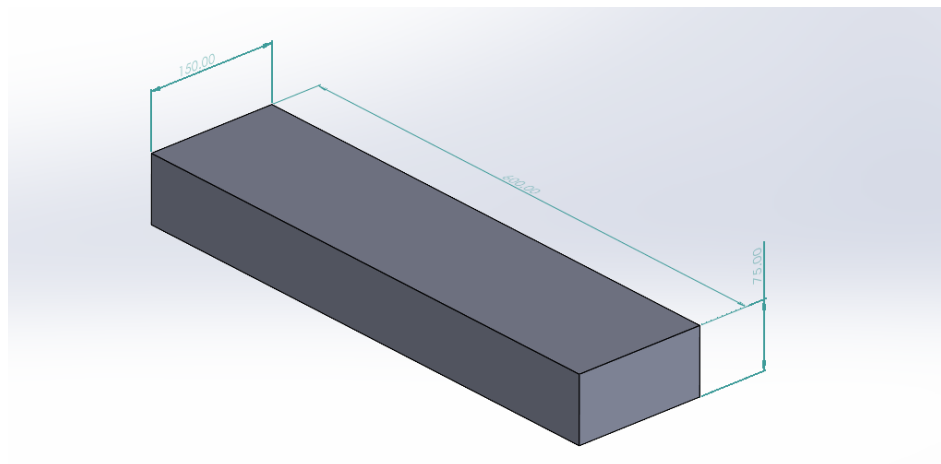

Major vane stock 600mm X 150mm X 75mm

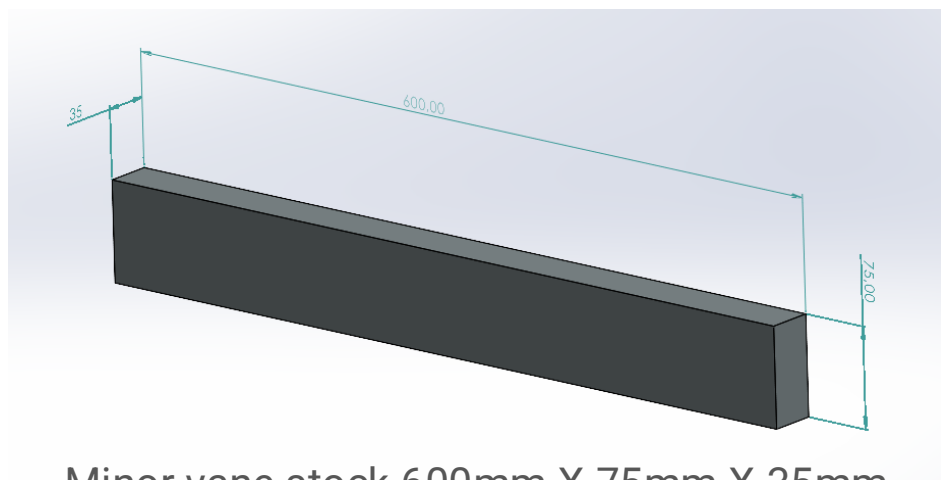

Minor vane stock 600mm X 75mm X 35mm

Minor vane stock provided by LUVATA Pori

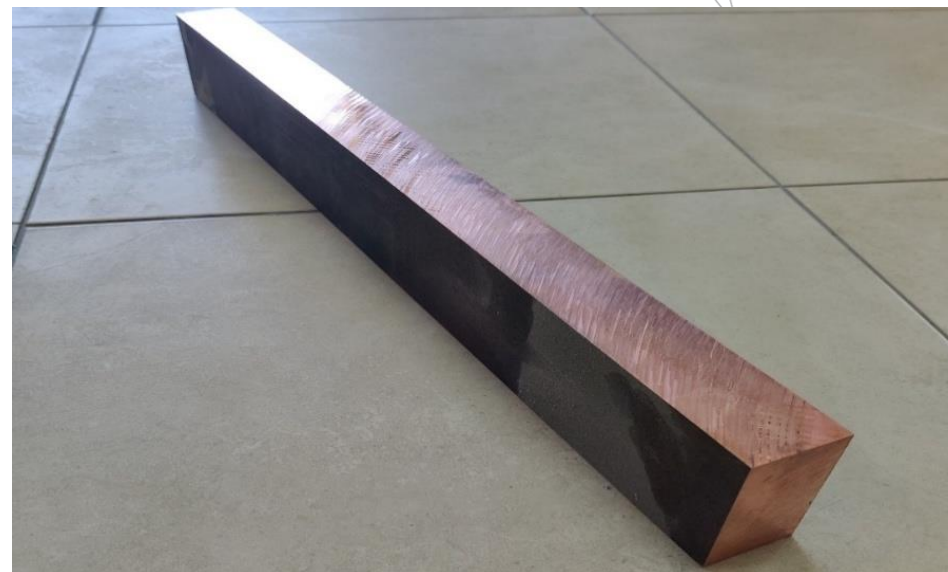

Technical Specification

N° 2001 - Ed. 8
EDMS No: 790779

Oxygen-Free Electronic copper
Bars/blanks/ingots

Cu-OFE



Minor vane machining stages

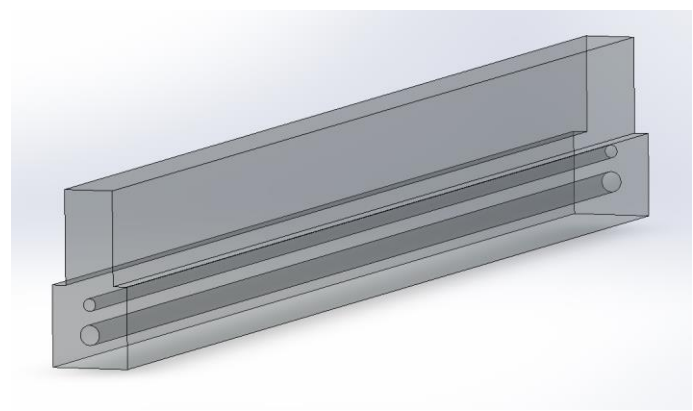

Pre-rough machining 3mm offset

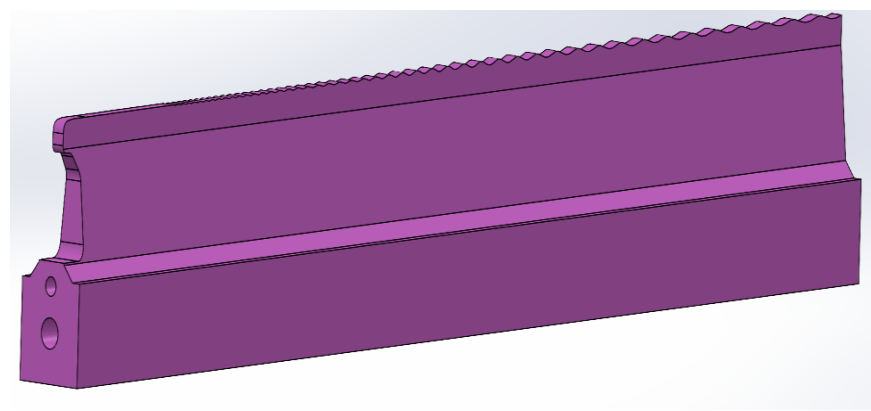

Rough machining 1mm offset

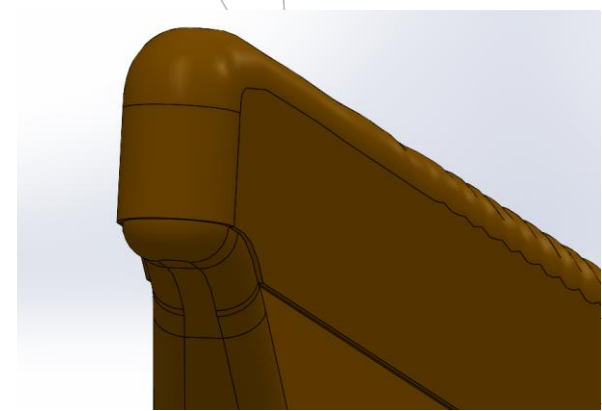

Pre-finishing, 0.15mm excess material on the modulation

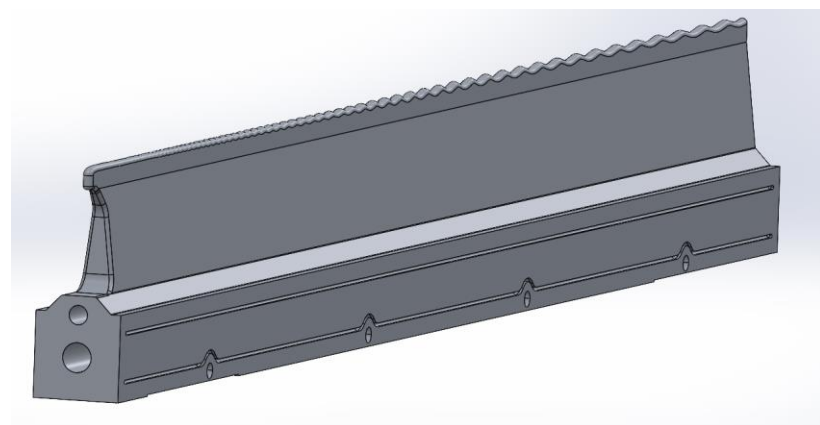

Finished minor vane before brazing

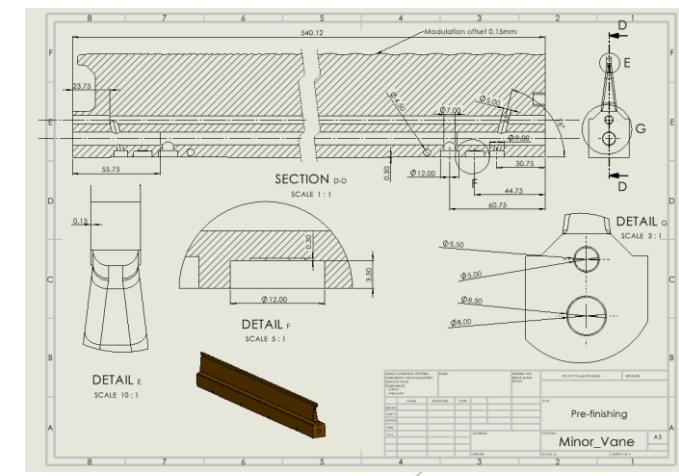

Pre-finishing, mechanical drawing



Major vane machining stages

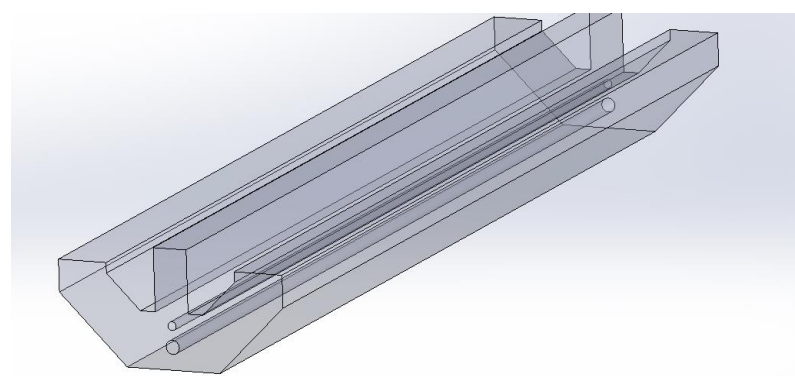

Pre-rough machining 3mm offset

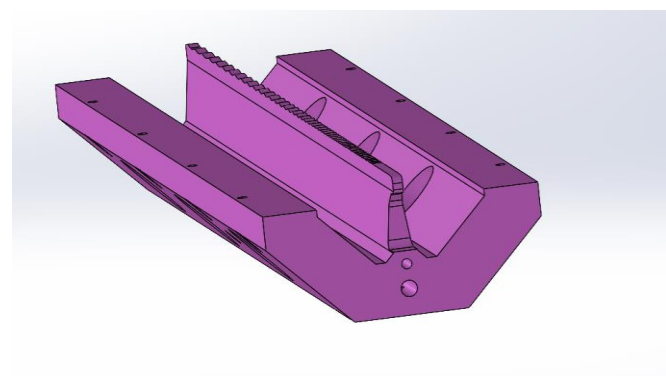

Rough machining 1mm offset

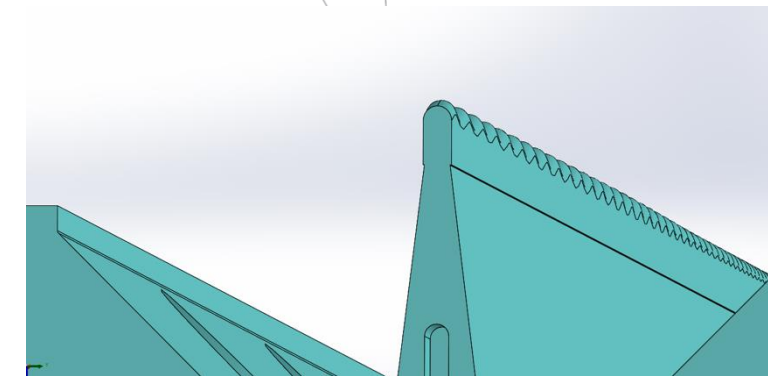

Pre-finishing, 0.15mm excess material on the modulation

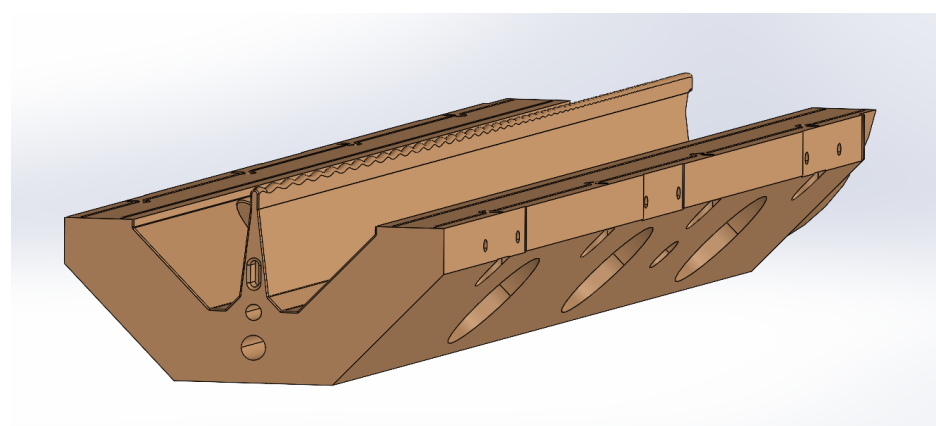

Finished minor vane before brazing

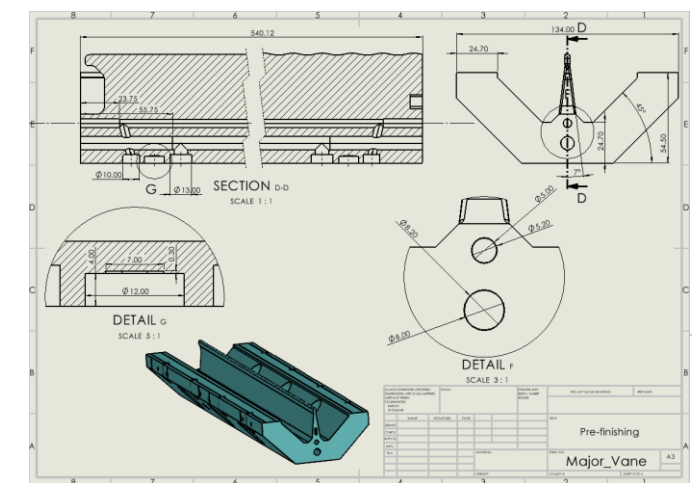

Pre-finishing, mechanical drawing

Modulation machining principle

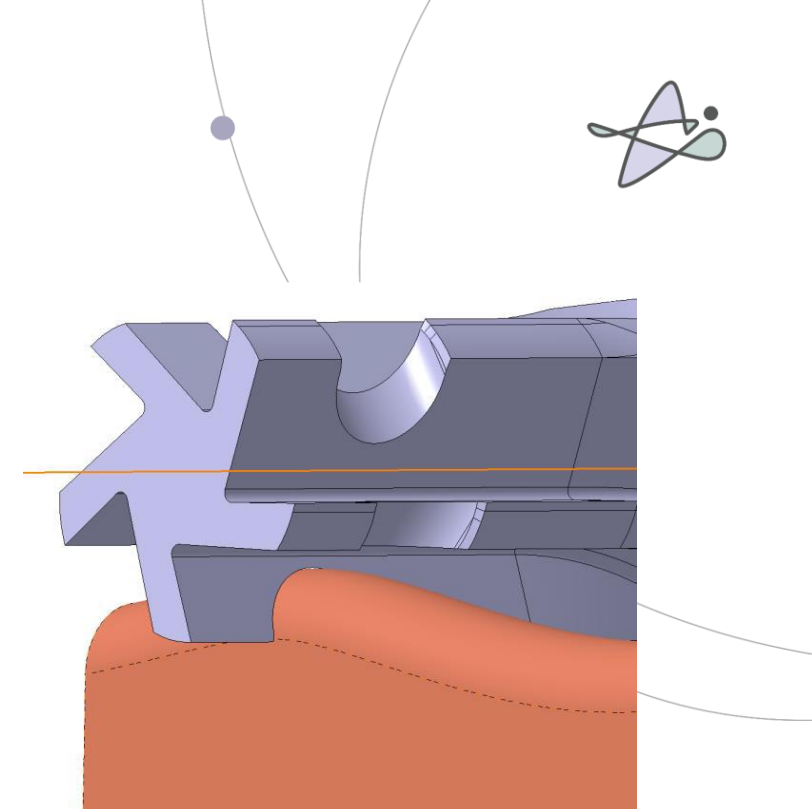

Modulation finishing principle



Heat treatment

The heat treatment processes between the machining stages will take place in a vacuum oven provided by our external partner MATREX.



Thank you for your attention



This project has received funding from the European Union's Horizon Europe Research and Innovation Programme under the Grant Agreement No.101186921.

ifigeneia.eu